

# CARES Technical Approval Report TA1-B & C 5059

Issue 3



Dextra

## DEXTRA Griptec Anchors

Assessment of the  
Griptec Anchors Product  
and Quality System  
for Production

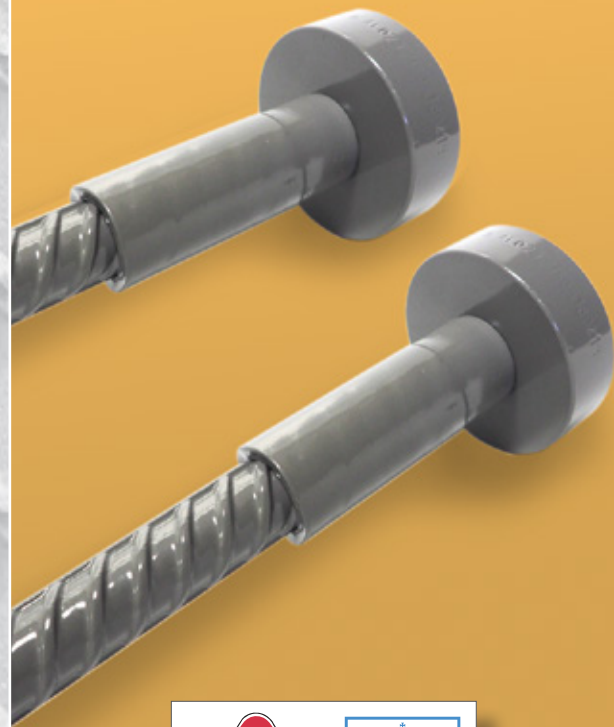

# Product

## DEXTRA Griptec Anchors for reinforcing steel

### Product approval held by:

DEXTRA Manufacturing Co. Ltd,  
191 Chalermprakit Rama 9,  
Soi 48,  
Pravet,  
Bangkok 10250,  
Thailand

Tel: +66 2328 0211-7 Fax: +66 726 2980

## 1 Product Summary

Griptec large, small and bolted headed bar anchor ranges are for the mechanical connection of deformed steel bars for the reinforcement of concrete complying with the requirements of BS4449 Grade B500C.

### 1.1 Scope of Application

Griptec large, small and bolted headed bar anchor ranges have been evaluated for use as follows:

- a) Small End Anchor 16mm - 40mm diameter bar:  
TA1-B Reinforcement Anchors for EN1992-1-1 applications for Static Loading in tension and  
TA1-C: Anchors for reinforcing steel for Sellafield Standard Applications only with BS4449 Grade B500C reinforcement in tension.
- b) Large End Anchor 12mm - 32mm diameter bar:  
TA1-B Reinforcement Anchors for EN1992-1-1 applications for Static Loading with BS4449 Grade B500C reinforcement in tension.
- c) Large End Anchors 12mm - 25mm diameter bar:  
TA1-C Anchors for reinforcing steel for Sellafield Standard Applications only with BS4449 Grade B500C reinforcement in tension.
- d) Bolted Headed Bar Anchors 32mm - 40mm diameter:  
TA1-C Anchors for reinforcing steel for Sellafield Standard Applications only with BS4449 Grade B500C reinforcement in tension.

### 1.2 Design Considerations

Eurocode 2, Clause 8.4 Anchorage of longitudinal reinforcement requires:

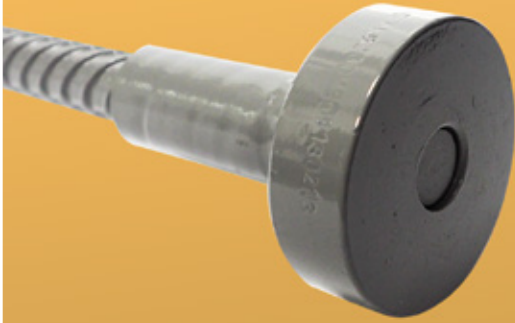

8.4.1 General

(1)P Reinforcing bars, wires or welded mesh fabrics shall be so anchored that the bond forces are safely transmitted to the concrete avoiding longitudinal cracking or spalling. Transverse reinforcement shall be provided if necessary.

8.4.1 (5) (5) Where mechanical devices are used the test requirements should be in accordance with the relevant product standard or a European Technical Approval.

The specified cover for fire resistance and durability should be provided to the coupler sleeve. All couplers have been designed with controlled mechanical properties to be compatible with reinforcing bars complying with reinforcement of the relevant Grade in accordance with BS4449.

**1.3 Conclusion**

It is the opinion of CARES that DEXTRA Griptec large, small and bolted headed bar anchors to reinforcing steel are satisfactory for use within the limits stated in paragraph 1.1 when applied and used in accordance with the manufacturer’s instructions and the requirements of this certificate.

L. Brankley  
 Chief Executive Officer  
 March 2021



Electronic Copy www.ukcares.com

## 2 Technical Specification

### 2.1 General

The function of DEXTRA Griptec anchors is to provide a full strength connection to deformed reinforcing steel bars complying with BS4449 Grade B500C and thereby enabling anchorage of reinforcing steel.

### 2.2 Griptec Small End Anchor Range

The small end anchor comprises a Griptec male sleeve and an anchor plate with an internal parallel thread matching the thread size on the male sleeve. The small heads, with a net bearing area of four times the cross-section area of the reinforcing bar, work with a combination of head bearing capacity and bond along the bar. The minimum anchorage length required to provide the bond must be computed according to the code provisions by the structural engineer, depending on the grade of reinforcement and the class of concrete.

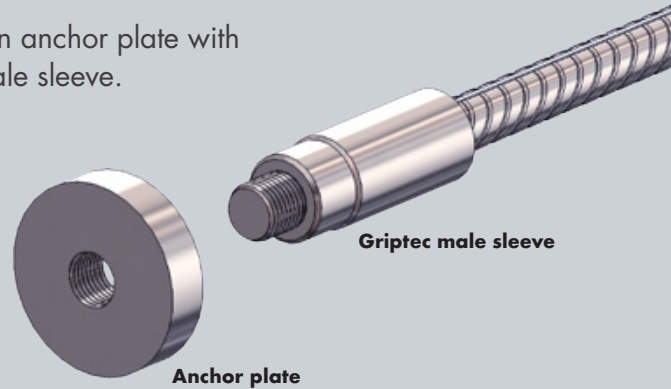

#### Small Anchor

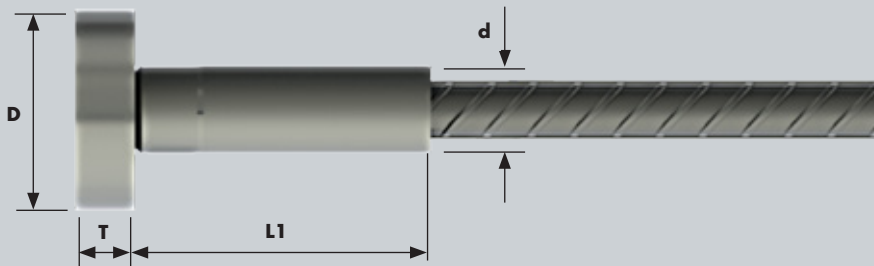

Size (mm)	Art No	d (mm)	L1 (mm)	D (mm)	T (mm)	Weight (kg)	Plastic protection colour	TA1-B B500C tension only	TA1-C Sellafield class
16	AGEASC16	25 to 26	99 to 103	42	16	0.2	White	✓	A
20	AGEASC20	29.5 to 32	107 to 110	52	20	0.4	Grey	✓	A
25	AGEASC25	37 to 39	112 to 125	65	22	0.7	Red	✓	A
32	AGEASC32	47 to 49	137 to 143	80	28	1.2	Brown	✓	A
40	AGEASC40	61 to 63	167 to 170	105	34	2.3	Green	✓	A

Table 1

### 2.3 Griptec Large End Anchor Range

The large end anchor comprises a griptec male sleeve and an anchor plate with an internal parallel thread matching the thread size on the male sleeve. The large heads, with a net bearing area of nine times the cross-section area of the reinforcing bar, are designed to develop the yield strength of the bars, without any contribution from bond along the bar. Large heads therefore allow designs where the critical section is closer to the head than the anchorage length would allow.

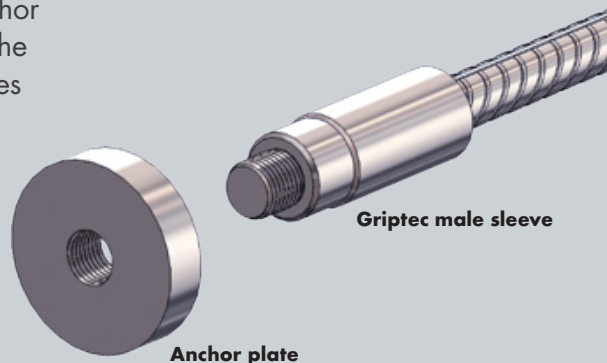

#### Large Anchor

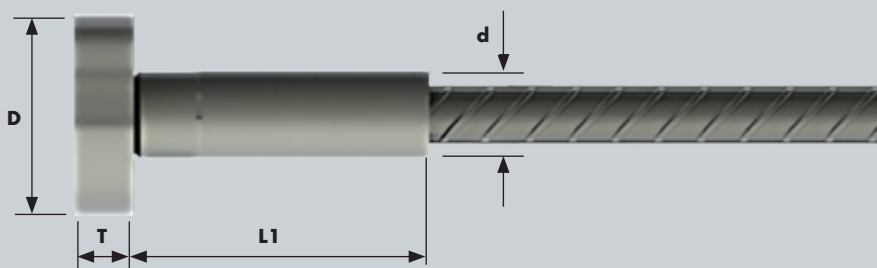

Size (mm)	Art No	d (mm)	L1 (mm)	D (mm)	T (mm)	Weight (kg)	Plastic protection colour	TA1-B B500C tension only	TA1-C Sellafield class
12	AGEALC12	19 to 20	66 to 72	45	12	0.15	Yellow	✓	A
16	AGEALC16	25 to 26	99 to 103	55	16	0.4	White	✓	A
20	AGEALC20	29.5 to 32	107 to 110	70	20	0.7	Grey	✓	A
25	AGEALC25	37 to 39	112 to 125	90	22	1.3	Red	✓	A
32	AGEALC32	47 to 49	137 to 143	110	32	2.6	Brown	✓	Not applicable

Table 2

Electronic Copy www.ukcares.com



## 2.4 Griptec Bolted Headed Bar Range

The bolted headed bar comprises a griptec female sleeve, anchor plate and hexagonal bolt with an external parallel thread matching the internal thread size in the female sleeve. The bolted end anchor plates are designed to fit with female Griptec sleeves.



**Bolted Headed Bar**

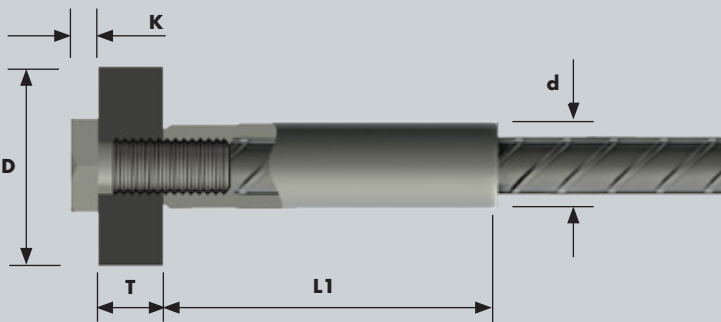

Size (mm)	Art No	D (mm)	T (mm)	L1 (mm)	d (mm)	K (mm)	Weight (kg)	Plastic protection colour	TA1-B B500C tension only	TA1-C Sellafield class
32	GEAB32	110	32	140	47 to 49	21	2.4	Brown	✓	A
40	GEAB40	140	35	170	61 to 63	26	4.2	Green	✓	A

**Table 3**



### 3 Product Performance and Characteristics

Full mechanical tests have been carried out to demonstrate compliance with the performance requirements defined in CARES Appendix TA1-B and TA1-C when used with reinforcing steel to BS4449 Grade B500C:

#### CARES APPENDIX TA1-B strength requirements

- Permanent deformation is less than 0.10mm after loading to  $0.65f_y$  in tension with BS4449 grade B500C reinforcement.
- 99% characteristic tensile strength is greater than 575 MPa with BS4449 Grade B500C steel reinforcement.

#### CARES APPENDIX TA1-C requirements

- Permanent deformation is less than 0.10mm after loading to  $0.65f_y$  in tension with BS4449 grade B500C reinforcement.
- Tensile strength of  $\geq 1.15$ ,  $\leq 1.35$  of the actual reinforcement yield strength ( $R_{e\ act}$ ) with BS4449 Grade B500B reinforcement. The ultimate tensile strength of the individual splice system of not less than the load necessary to produce 2% strain in the portion of the spliced bar adjacent to the coupler.
- Cold soak test: One tensile sample is tested at  $-7^\circ\text{C}$  or less.
- Low cycle fatigue of 100 cycles at 5% - 90%  $f_{yk}$

The evaluation considers the strength of the connection between the anchor and the reinforcing steel only and does not address aspects of anchor performance nor its connection to the structure which are matters for the designer or specifier.



## 4 Installation

### 4.1 Griptec Small and Large End Anchor Range

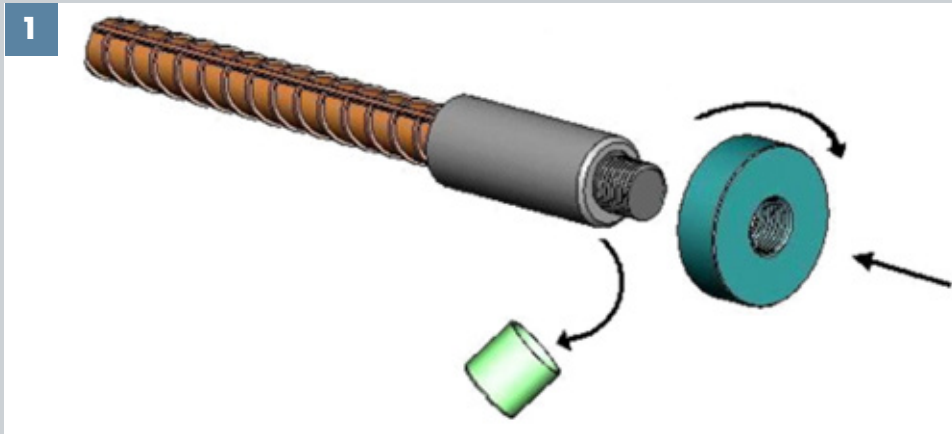

**Remove the plastic cap from the thread protection.**

**Screw the anchor plate onto the Griptec reinforcing bar.**

*Before screwing on the plate, check that the thread on the bar is not an extended thread meant for a position splice.*

### 4.2 Griptec Bolted Headed Bar Range

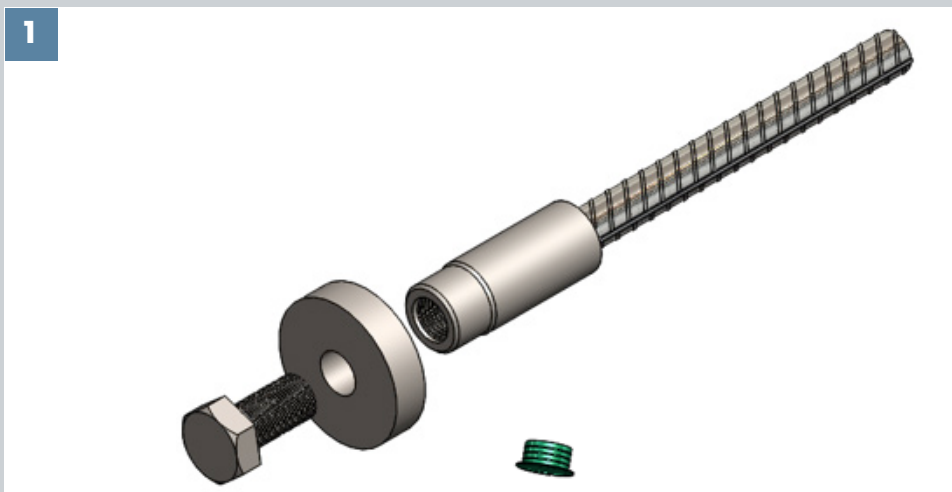

**Remove the plastic cap from the thread protection.**

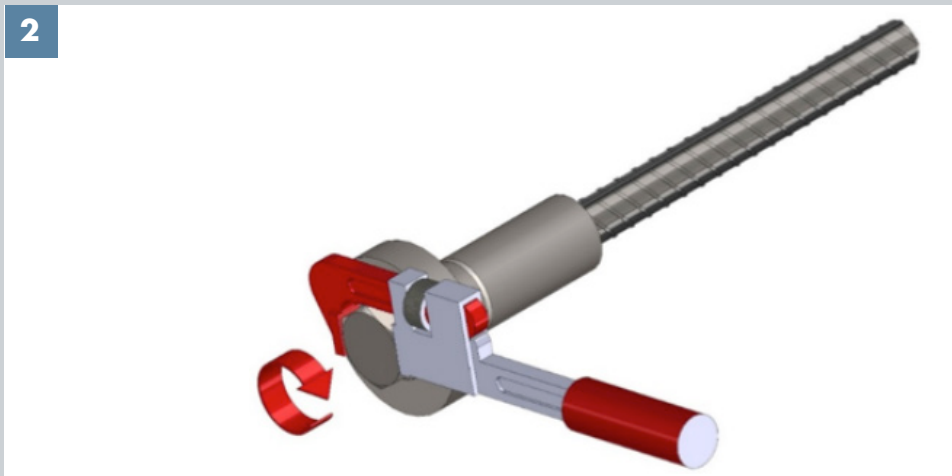

**Hand screw the bolt through the anchor plate into the Griptec female sleeve.**

**Tighten it with a pipe wrench.**



## 5 Safety Considerations

Couplers and anchorages are supplied in wooden containers and have a maximum weight 1500 kg and must be handled with appropriate lifting equipment. It is advisable to wear protective gloves during handling the containers, couplers and reinforcement; during the swaging process and during coupler installation.

## 6 Product Testing and Evaluation

DEXTRA Griptec anchors for reinforcing steel have been subject to mechanical testing to satisfy the requirements of CARES Appendix TA1-B & TA1-C for anchors with BS4449 Grade B500C reinforcing steel.

## 7 Quality Assurance

DEXTRA Griptec anchors to reinforcing steel are produced under an EN ISO 9001 quality management system certified by CARES at locations agreed with CARES. The quality management system scheme monitors the production of the anchors and ensures that materials and geometry remain within the limits of this technical approval.

The products are subject to a programme of periodic testing to ensure continued compliance.



## 8 Building Regulations

### 8.1 The Building Regulations (England and Wales)

#### Structure, Approved Document A

DEXTRA Griptec anchors to reinforcing steel, when used in EC2 based designs using the data contained within this technical approval, satisfy the relevant requirements of The Building Regulations (England and Wales), Approved Document A.

#### Materials and Workmanship, Approved Document

This technical approval gives assurance that the DEXTRA Griptec anchors to reinforcing steel comply with the material requirements of EC2.

### 8.2 The Building Regulations (Northern Ireland)

#### Materials and Workmanship

This technical approval gives assurance that DEXTRA Griptec anchors to reinforcing steel, comply with the material requirements of EC2 by virtue of regulation 23, *Deemed to satisfy provisions regarding the fitness of materials and workmanship.*

### 8.3 The Building Standards (Scotland)

#### Fitness of Materials

This technical approval gives assurance that DEXTRA Griptec anchors to reinforcing steel comply with the material requirements of EC2 by virtue of *Clause 0.8.*

#### Structure

DEXTRA Griptec anchors to reinforcing steel, when used in EC2 based designs using the data contained within this technical approval, satisfy the requirements of *The Building Standards (Scotland) Clause 1.*

## 9 References

- BS4449: 2005 Stainless steel bars for the reinforcement of and use in concrete - Requirements and test methods.
- BS EN 1992-1-1:2004 Eurocode 2 Design of concrete structures - General rules for buildings.
- BS EN ISO 9001: Quality management systems - Requirements.
- CARES Appendix TA1-B: Quality and Operations Schedule for the Technical Approval of Couplers for Reinforcing Steel and Reinforcement Anchors For BS8110 and EN1992-1-1 Applications for Static Loading in Tension or Tension and Compression.
- CARES Appendix TA1-C: Quality and Operations Schedule for the Technical Approval of Tension or Tension-compression Couplers for Reinforcing Steel and Reinforcement Anchors for Sellafield Standard Applications.



## 10 Conditions

1. The quality of the materials and method of manufacture have been examined by CARES and found to be satisfactory. This technical approval will remain valid providing that:
  - a. The product design and specification are unchanged.
  - b. The materials, method of manufacture and location are unchanged.
  - c. The manufacturer complies with CARES regulations for technical approvals.
  - d. The manufacturer holds a valid CARES Certificate of Product Assessment.
  - e. The product is installed and used as described in this report.
2. CARES make no representation as to the presence or absence of patent rights subsisting in the product and/or the legal right of DEXTRA to market the product.
3. Any references to standards, codes or legislation are those which are in force at the date of this certificate.
4. Any recommendations relating to the safe use of this product are the minimum standards required when the product is used. These requirements do not purport to satisfy the requirements of the Health and Safety at Work act 1974 or any other relevant safety legislation.
5. CARES does not accept any responsibility for any loss or injury arising as a direct or indirect result of the use of this product.
6. This Technical Approval Report should be read in conjunction with CARES Certificate of Product Assessment No 5059. Confirmation that this technical approval is current can be obtained from UK CARES.



Electronic Copy www.ukcares.com



**UK CARES**

Pembroke House  
21 Pembroke Road  
Sevenoaks  
Kent TN13 1XR

Phone: +44(0)1732 450000  
E-mail: [general@ukcares.com](mailto:general@ukcares.com)  
URL: [www.ukcares.com](http://www.ukcares.com)

**Independent Product Assessments  
for the Construction Industry**

Copyright UK CARES ©