

CARES Technical Approval Report TA2 5075



Issue 2



DYWIDAG-SYSTEMS INTERNATIONAL recostal® RSH Key Profiled EC2 Starter Pack

Assessment of the
DYWIDAG-Systems International
recostal® RSH Key Profiled EC2
Starter Pack Product
and Quality System
for Production

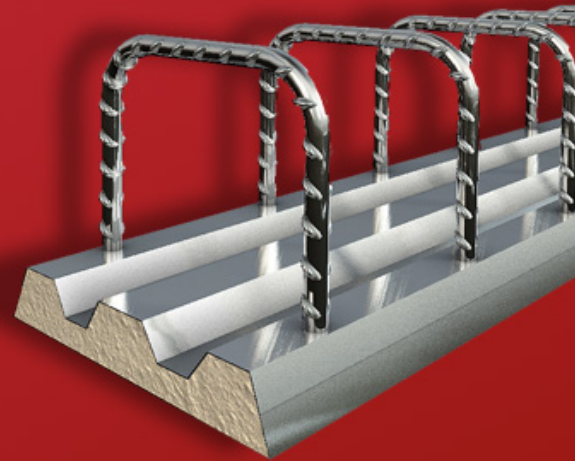

Product

DYWIDAG-Systems International recostal® RSH Key Profiled EC2 Starter Pack Reinforcement Continuity System

Product approval held by:

DYWIDAG-Systems International Ltd.,
Northfield Road, Southam,
Warwickshire,
CV47 0FG
Tel: 01926 813980
Fax: 01926 812273
Email: sales@dy.co.uk

1 Product Summary

DYWIDAG-Systems International recostal® RSH Key Profiled EC2 Starter Packs consist of specially selected pre-bent reinforcement housed in a uniquely trapezoidal profiled corrosion resistant casing, this is designed to provide continuity over construction joints while providing the highest key (indented) profile at the joint according to “BS EN 1992 1-1 Eurocode 2: Design of Concrete Structures”.

The unit is cast into the front face of the first concrete pouring section. After the formwork is struck, the backing is removed to reveal the starter bars inside. These legs are then bent out by the contractor and lapped onto the main reinforcement of the next pour.

The rear casing remains embedded in the first concrete pouring section, providing a trapezoidal profiled rebate into which the concrete is poured. This eliminates the need for traditional preparation at the joint. Trapezoidally profiled construction joints according to EC2 represent the highest category with regard to the transfer of shear forces.

1.1 Scope of Application

DYWIDAG-Systems International recostal® RSH Key Profiled EC2 Starter Pack system with bar diameters ranging from 10mm to 16mm has been evaluated in accordance with the “BS EN 1992 1-1 Eurocode 2: Design of Concrete Structures”.

1.2 Design Considerations

DYWIDAG-Systems International recostal® RSH Key Profiled EC2 Starter Pack system product types are used in UK construction as a jointing method that requires construction sites to bend in-situ reinforcement bars.

The design recommendations in “BS EN 1992 1-1 Eurocode 2: Design of Concrete Structures.” Can be applied to all aspects of this product with particular attention being paid to the sections relating to bearing stresses (8.3), anchorage (8.4) and primarily for this product (6.2.5) Shear at the interface between concrete cast at different times.

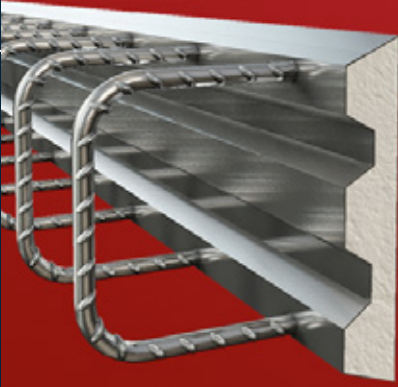

1.3 Conclusion

It is the opinion of CARES the DYWIDAG-Systems International recostal® RSH Key Profiled EC2 Starter Pack reinforcement continuity system is satisfactory for use within the limits stated in paragraph 1.1 when installed and used in accordance with the manufacturer's instructions and the requirements of this certificate.

L. Brankley
Chief Executive Officer
May 2023

Electronic Copy www.carescertification.com



2 Technical Specification

2.1 General

The DYWIDAG-Systems International recostal® RSH Key Profiled EC2 Starter Pack system only, meet the requirements of BS EN 1992-1-1 for the highest surface category “key profiled“ in the case of transverse loads.

Key Profiled EC2 Starter Pack type recostal® RSH is for the transverse shear load for example at wall-to-floor applications. This Technical Report is for recostal® RSH Key Profiled EC2 Starter Pack system only, recostal® type RSV is not covered by this technical approval.

Features:

- Trapezoidal profiled starter packs, joint category “key profiled“ according to BS EN 1992-1-1, highest shear force bearing capacity
- Concrete reinforcement steel B500B or according to BS4449, $\varnothing = 10\text{mm} - 16\text{mm}$ for RSH
- Diameter of bending rolls $d_{br} \geq 6 D_s$ in the section of rebending
- Many standard profiles
- Standard unit length $L = 1.25\text{m}$, fixed lengths up to 2.50m on request
- Special types and sizes on request

The types of reinforcement are according to BS4449 Grade B500B. The material is CARES approved, assuring consistent compliance with the product standard. Material processing is CARES approved to ensure full traceability from steel mill to construction site.

The recostal® RSH consists of:

- Strong, robust galvanised sheet metal casing, dimensionally stable
- Cost and time effective installation, starter packs are simply nailed to the formwork
- Easy removal of the sheet metal covers due to their special design
- Trapezoidal profiled box for excellent bond can reduce steel congestion when compared with other categories of holding cases
- Various possible combinations provide a solution for all common installation details

DYWIDAG-Systems International recostal® RSH Key Profiled EC2 Starter Pack meets the requirements set out in “BS EN 1992 1-1 Eurocode 2: Design of Concrete Structures (6.2.5) Shear at the interface between concrete cast at different times.” By using the specified profile for the holding case see figure 1.

recostal® RSH Key Profiled EC2 Starter Pack RSH Reinforcement Continuity System

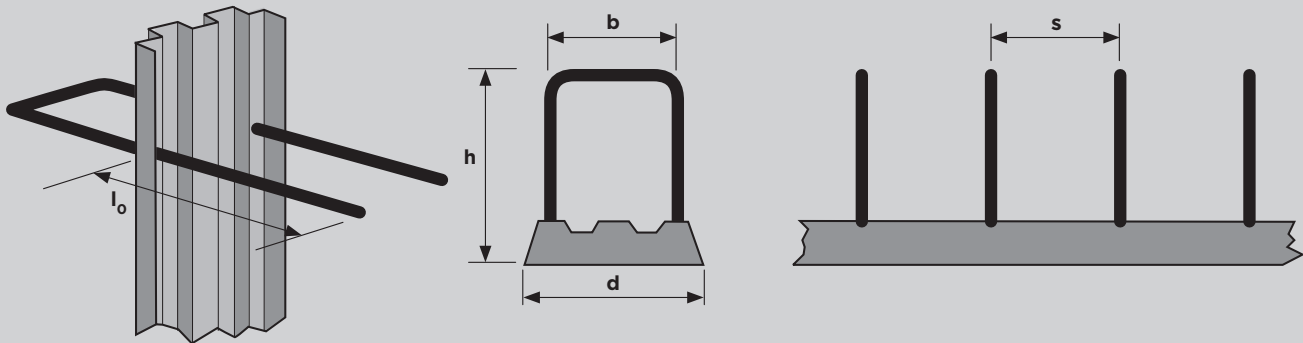

recostal® TYPE RSH

Type/Shape	∅ Bar (mm)/ s (mm)	Lap Length l ₀ (mm)	Bar Height h (mm)	Bar Width b (mm)	Effective Depth d (mm)
RSH 10	10/150	410	170	100	130
	10/200	410	170	100	130
	12/150	500	170	100	130
	12/200	500	170	100	130
RSH 11	10/150	410	170	110	140
	10/200	410	170	110	140
	12/150	500	170	110	140
	12/200	500	170	110	140
RSH 12	10/150	410	170	120	150
	10/200	410	170	120	150
	12/150	500	170	120	150
	12/200	500	170	120	150
RSH 14	10/150	410	170	140	170
	10/200	410	170	140	170
	12/150	500	170	140	170
	12/200	500	170	140	170
	16/200	650	170	140	170
RSH 16	10/150	410	170	160	190
	10/200	410	170	160	190
	12/150	500	170	160	190
	12/200	500	170	160	190
	16/200	650	170	160	190
RSH 18	10/150	410	170	180	210
	10/200	410	170	180	210
	12/150	500	170	180	210
	12/200	500	170	180	210
	16/150	650	170	180	210
	16/200	650	170	180	210
RSH 20	10/150	410	170	200	230
	10/200	410	170	200	230
	12/150	500	170	200	230
	12/200	500	170	200	230
	16/150	650	170	200	230
	16/200	650	170	200	230
RSH 22	10/150	410	170	220	250
	10/200	410	170	220	250
	12/150	500	170	220	250
	12/200	500	170	220	250
	16/150	650	170	220	250
	16/200	650	170	220	250

Table 1 - Standard recostal® TYPE RSH

Electronic Copy www.carescertification.com

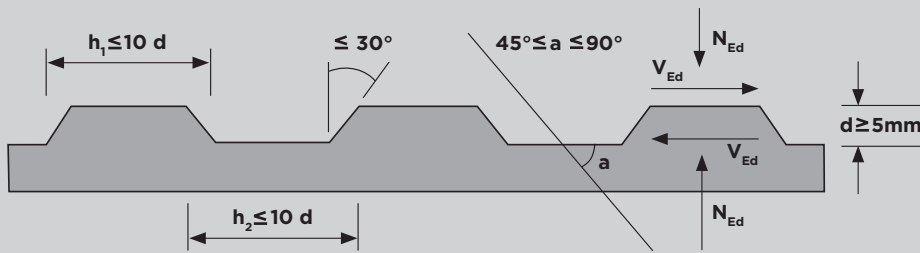

Figure 1 - recostal® TYPE RSH geometry of key profiled joints according to EC2

EC2 divides the type of joint surface into 4 categories. Trapezoidal profiled construction joints represent as utilised by DYWIDAG-Systems International recostal® RSH Key Profiled EC2 Starter Pack the highest category with regard to the transfer of shear forces. See Table 2 below.

Type of surface according to EC2 § 6.2.5 (2)	Roughness coefficient $c^{1)}$	Friction coefficient μ	Strength reduction coefficient $v^{3)}$
Key profiled joint	0.5	0.9	0.7
Rough joint	0.4 ²⁾	0.7	0.5
Smooth joint	0.2 ²⁾	0.6	0.2
Very smooth joint	0	0.5	0 ⁴⁾

Table 2 - Classification of joint surfaces according to [R1], 6.2.5 Roughness coefficient c and friction coefficient Q

It should be noted that the type of Testing carried out at Imperial College on the recostal® RSH system did not test the shear design resistance and is therefore unable to qualify or confirm the above roughness coefficient for the recostal® RSH system due to lack of data.

- 1) In case of dynamic or fatigue loading, the concrete bond (adhesion) should not be taken into consideration ($c = 0$).
- 2) Where tension occurs perpendicular to the join due to impact, $c = 0$.
- 3) For concrete classes $\geq C55/67$, the stated values are to be multiplied by the factor $(1.1 - f_{ck}/500)$ with f_{ck} in $[N/mm^2]$.
- 4) The friction proportion in Expression 6.25 may be allowed for up to the limit of $\mu \cdot \sigma_N \leq 0.1 f_{cd}$.

It is assumed that all joints be assumed to be smooth unless otherwise stated in the technical approval document according to BS EN 1992-1-1.

The manufacturers literature and full technical data sheet offers more detail and scheduling advise for the specifying engineer and contractor.

The manufacturing process complies fully with BSEN ISO 9001 and bars are bent and cropped according to BS8666.

recostal® RSH Shape Variations

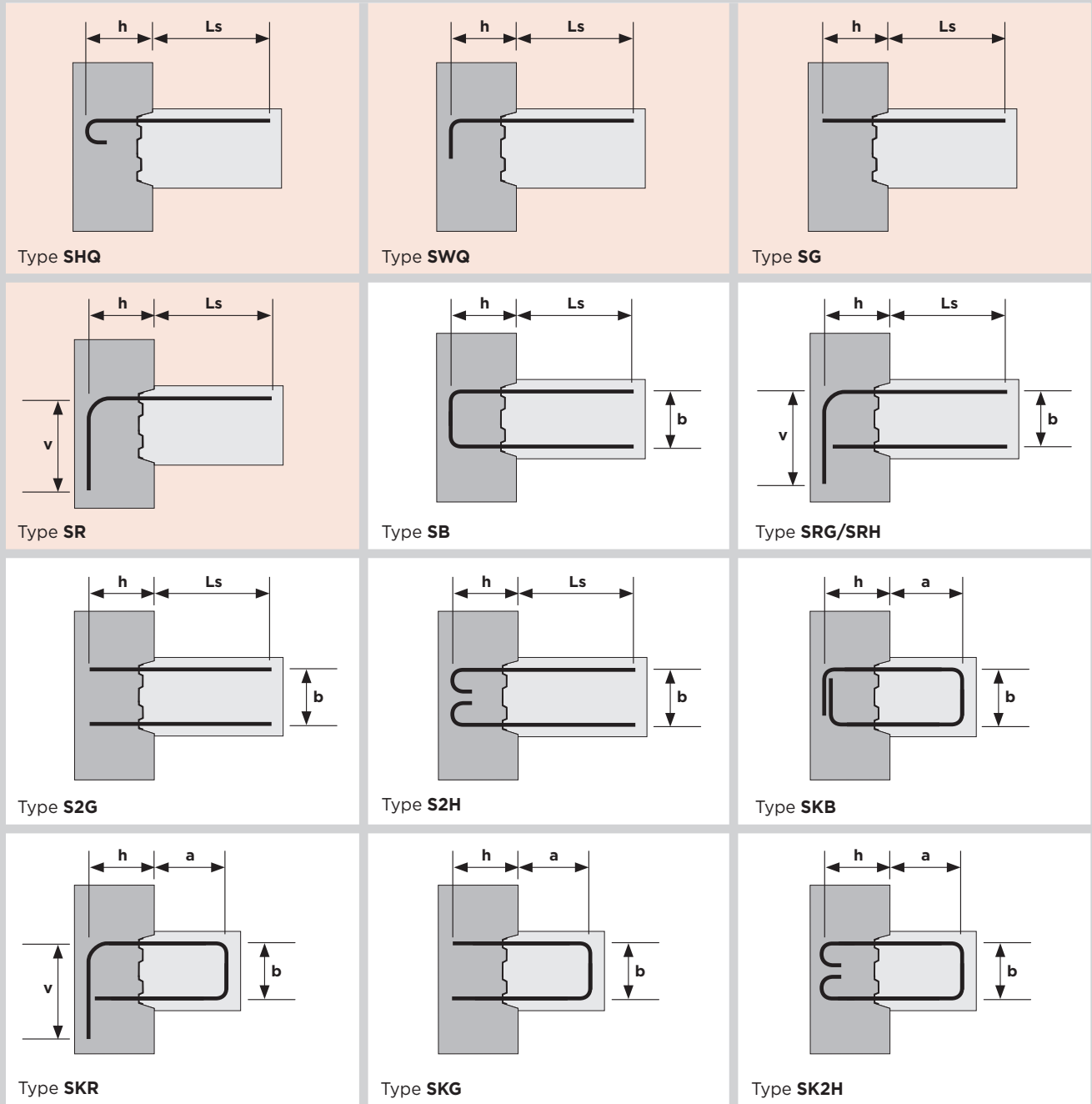

Figure 2

Orange background: Key profiled EC2 Box on request.

White background: Covered by this technical approval.



Electronic Copy www.carescertification.com

3 Product Performance and Characteristics

3.1 Reinforcement Tensile Properties

Mechanical tests on the reinforcement showed that the material, after bending and straightening, complied with the tensile requirements of BS4449 Grade B500B, exhibiting values for Total Elongation at Maximum Load (A_{gt}) of greater than 5%.

3.2 Structural Performance

Structural tests of wall/floor sub-frames and push-off specimens simulating joints between adjacent parts of walls showed that:

- 1) The shear strengths of the slabs, which were without shear reinforcement, could be safely calculated in accordance with EC2 (eqn 6.2a). There were no shear failures associated with the joints.
- 2) The flexural strengths of the wall/floor connections could be safely calculated on the basis of EC2's section 6.1 (Bending with or without axial force) and section 8 (Detailing of reinforcement) with the latter interpreted as in this report.
- 3) The widths of openings, that may develop at the rear faces of casings and between the ends of floor slabs and the faces of walls at the serviceability state, could be calculated as:

$$w = \frac{(y - x) \sigma_s^2 \phi}{(d - x) 4E_s \tau}$$

where

- σ_s is the stress in the tension reinforcement of the slab at the face of the wall
- ϕ is the bar diameter
- E_s is the elastic modulus of steel (200×10^3 MPa)
- $\tau = 0.5 f_{ck}^{2/3}$ for short-term loading or $0.4 f_{ck}^{2/3}$ for long-term loading
- x is the cracked-elastic neutral axis depth
- d is the effective depth of the reinforcement (measured from the underside of the slab)
- y is the vertical distance from the underside of the slab to the level for which the width of the opening is calculated

4 Installation

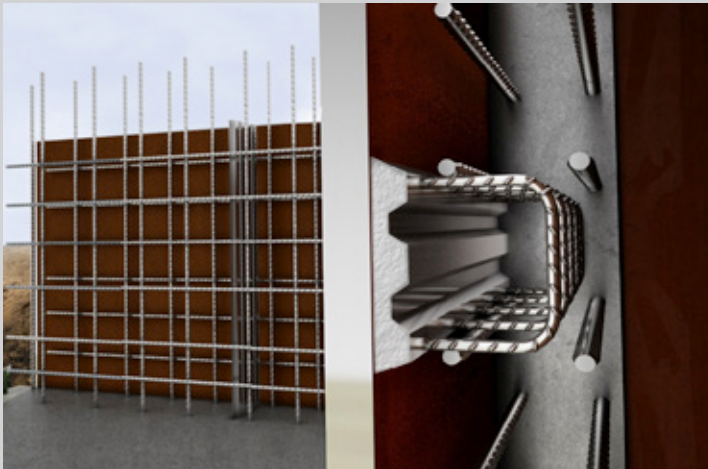

1 Fix to Formwork

Fix recostal® TYPE RSH into position on the formwork prior to pouring concrete.

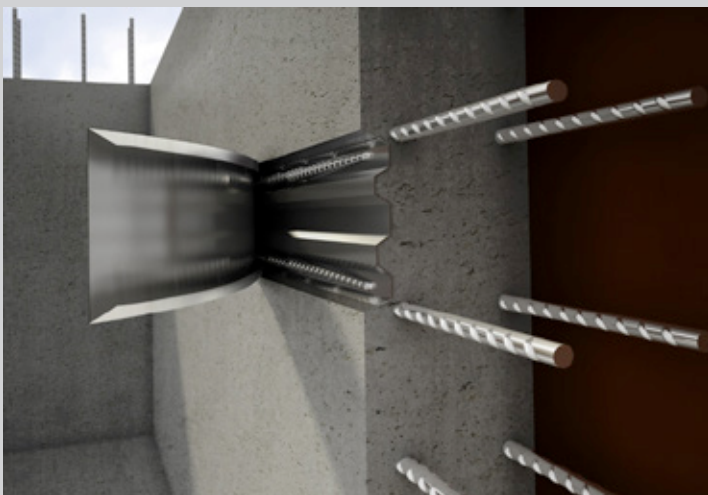

2 After First Pour Remove the Casing

Remove the casing to reveal the reinforcement bars which are ready to be straightened.

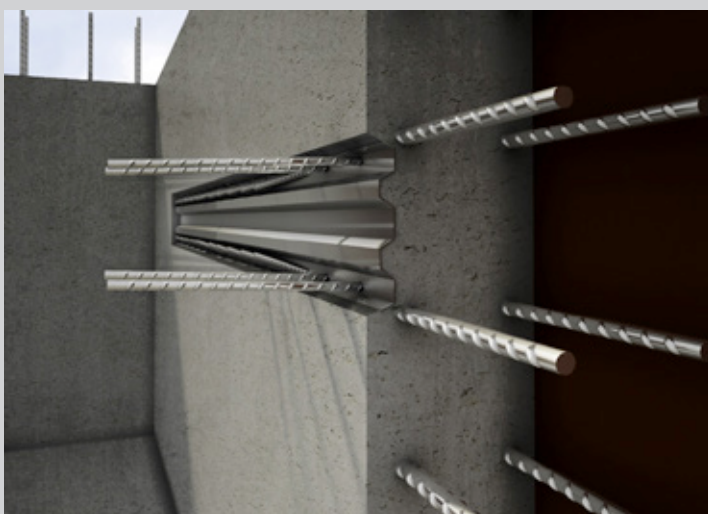

3 Straighten Reinforcement Bars

Bend out the reinforcement bars using a rebending tube, see section 4.2 for more details.



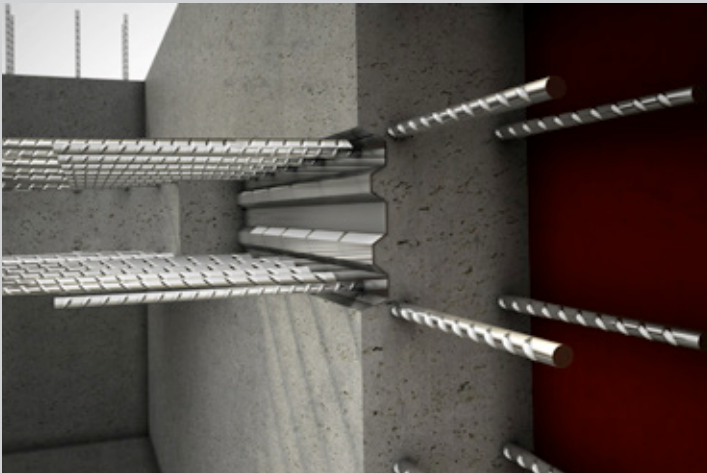

4 Create Overlapping

Straighten all reinforcement bars ready for lapping on to the main reinforcement prior to the 2nd pour.

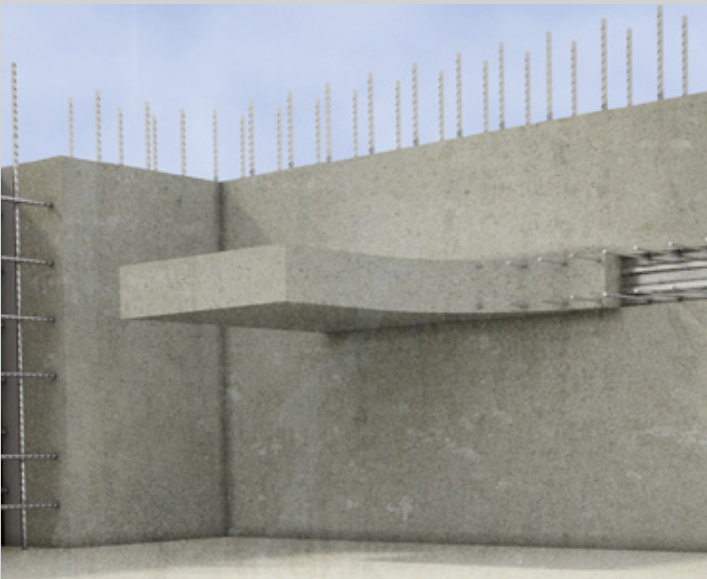

5 2nd Pour

The casing remains embedded in the wall providing a key profile for the 2nd pour.

4.2 Straightening/Counterbending of Bars

Rebending of reinforcing steel and requirements for boxes according to EC2

	Start of Rebending	After Rebending	Assessment
a			<p>Correct</p>
b			<p>Correct</p>
c			<p>Wrong</p>
d			<p>Wrong</p>

Electronic Copy www.carescertification.com

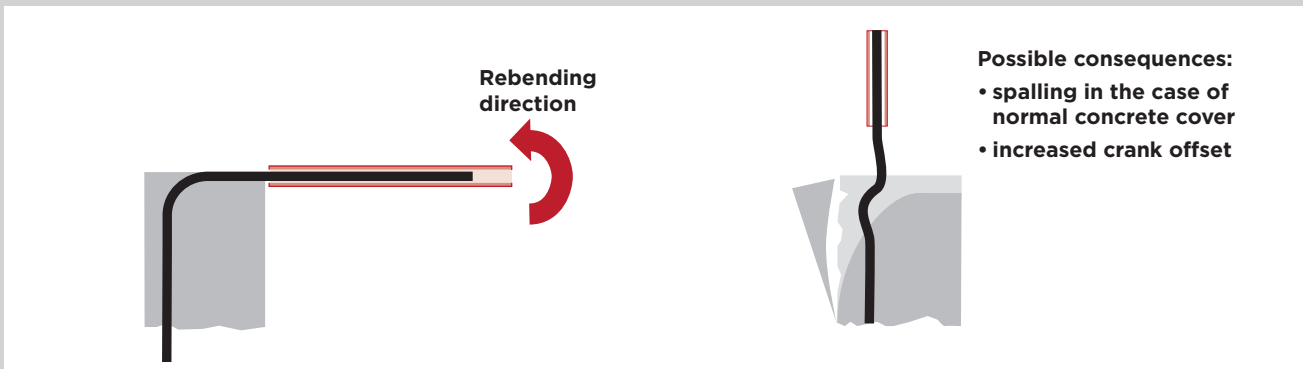

Case	Rebending direction	Assessment
<p>a</p>		<p>Favourable</p>
<p>b</p>		<p>Favourable</p>
<p>c</p>	<p>Spalling possible</p>	<p>Non favourable</p>

4.3 Storage

The recostal® system units should be safely stored on site on pallets and protected from corrosion and mechanical deterioration by waterproof sheeting.

5 Safety Considerations

Protective gloves should be worn at all stages when handling recostal® system units. This is particularly important when removing sharp-edged steel lids. Safety glasses should also be worn when straightening the bars. Heavy units (i.e. those above 25 kg) should be handled by two operatives. As previously stated, if there is likely to be an appreciable delay between straightening the bars and lapping the main reinforcement, and there is a perceived risk of injury from projecting bars, then they should have proprietary safety caps placed over their ends.



6 Product Testing and Evaluation

6.1 General

The recostal® RSH Key Profiled EC2 Starter Pack reinforcement continuity system was evaluated in two stages:

- 6.1.1** The reinforcement was subject to independent mechanical testing to establish its suitability for bending during the prefabrication process and rebending through 90° degrees during the straightening process on site without surface rupture and for subsequent compliance with the tensile requirements of BS4449:2005 + A3: 2016.
- 6.1.2** recostal® RSH Key Profiled EC2 Starter Pack reinforcement continuity system samples were subject to a programme of full scale structural testing in concrete to evaluate the performance of the construction joints.

6.2 Mechanical Testing

The selected reinforcement was tested to determine the appropriate bend radii.

- 1) Reinforcement was subject to the CARES bendability test, which consisted of bending the reinforcement through 90° degrees over a steel former, straightening with the recostal® tool and examination of the inside of the bend for signs of fracture. The test was conducted twice on each sample.
- 2) Reinforcement was also subjected to the CARES tensile test regime, which consisted of bending the reinforcement through 90° degrees over a steel former and straightening with the recostal® tool prior to tensile testing to measure the Ultimate Tensile Strength, Yield Strength and Elongation at Maximum Load (A_{gt}). The selected reinforcement were found to comply with the tensile requirements of BS4449 Grade B500B according to Clause 7.2.3, Table 4.

The products are subject to a programme of periodic testing to ensure that they remain within the performance limits of this technical approval.

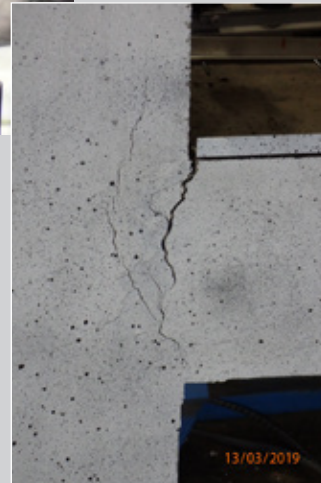
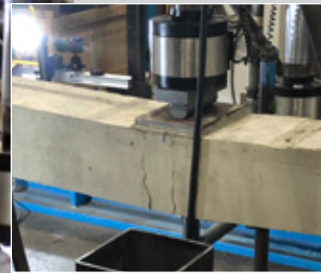
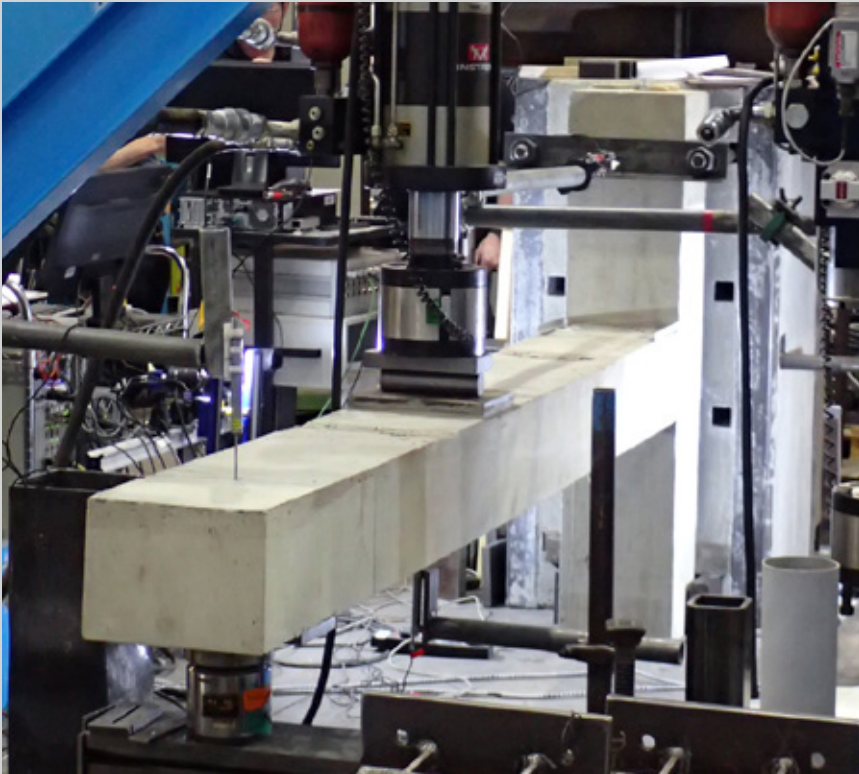

Figure 2 - Test arrangement

6.3 Full Scale Structural testing

Construction joints formed using the recostal® RSH Key Profiled EC2 Starter Pack reinforcement continuity system samples were subject to a programme of structural testing. Several wall to floor slab joints were subjected to vertical shear and bending and several wall to wall joints were subjected to longitudinal shear. The tests were full scale in terms of bar sizes and member depths.

The largest bar diameter 16mm bar was chosen for the majority of tests as being the largest bar size used in the recostal® RSH Key Profiled EC2 Starter Pack reinforcement continuity system and that which imposes the greatest stresses on the surrounding concrete and the most severe demands on the reinforcement in relation to bending and straightening.

The main conclusions are given in section 3.2.

Electronic Copy www.carescertification.com



6.3.1 Assessment of Anchorage

In the evaluation of the results of tests the interpretation of the Eurocode used in this assessment is as follows in terms of design stresses. (In evaluations experimental stresses have been compared with values obtained from the expressions for characteristic stresses with actual values of f_c and f_y replacing f_{ck} and f_{yk})

1. The applied stress $f_{s,Ed}$ at the loaded end of an anchorage is calculated from the design moment M_{Ed} at the section at the inner face of the wall.
2. The anchorage is taken to begin at the rear face of the casing.
3. The stress $f_{s,Rd}$ that can be resisted by an anchorage, of either of the types shown in Figure 2, is the lesser of two values, one corresponding to the limit on the compression stress in the concrete at the start of the bend (EC2 eqn 8.1) and the other corresponding to the bond capacity of the active anchorage length.
4. The bond resistance available throughout the active anchorage length is taken as

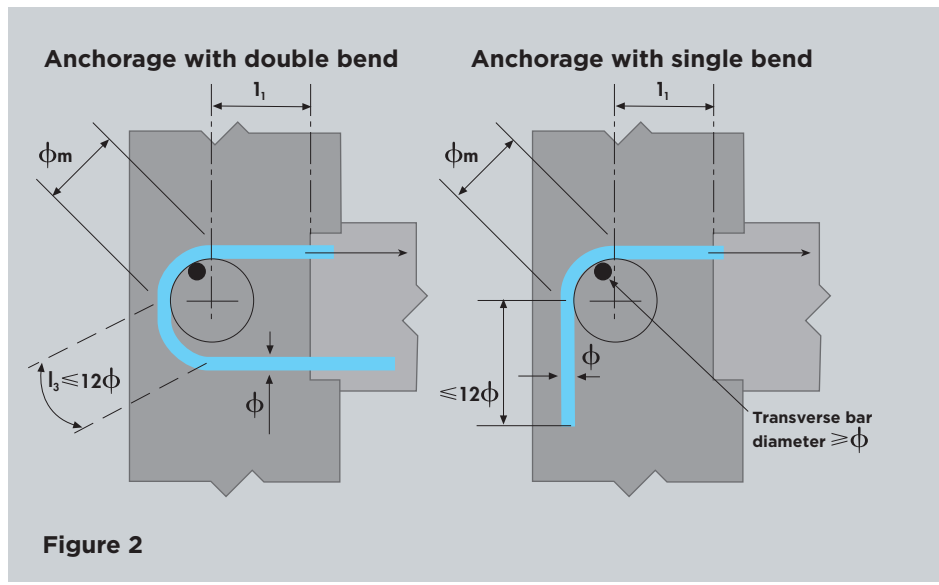

Figure 2

$$f_{b,Rd} = f_{bd} / \alpha_1 \alpha_2$$

where

f_{bd} is obtained from EC2's equation (8.2) using the strength of the wall concrete

$\alpha_1 = 0.7$ for a bent anchorage with $c_d \geq 3\phi$ (EC2 table 8.2)

$\alpha_2 = 1 - 0.15 [(c_d/\phi) - 3] \geq 0.7$ (EC2 table 8.2)

where

c_d for bent bars is the lesser of half the clear bar spacing and the clear side cover

5. The bar force which can be resisted at the start of the bend follows from equation (8.1) as

$$\frac{\phi \phi_m f_{cd}}{0.5 + \phi / a_b}$$

where

ϕ is the bar diameter

ϕ_m mandrel diameter (= 2 x internal radius of bend)

a_b lesser of distance from centre of bar to a concrete face parallel to the plane of the bend and half the centre to centre spacing of the bars

6. The additional force that can be developed between the rear face of the casing and the start of the bend is $f_{b,Rd} \times \pi\phi l_1$, where l_1 is the length from the rear of the casing to the bend. Thus the resistance as governed by consideration of bearing stresses is

$$F_{s,Rd1} = F_{bt,Rd} + f_{b,Rd} \cdot \pi\phi l_1$$

7. The value of $F_{s,Rd2}$, the resistance determined by the overall bond capacity, is

$$F_{s,Rd2} = f_{b,Rd} \cdot \pi\phi (l_1 + l_2 + l_3)$$

where

l_2 is the length within the bend $(\pi/8)(\phi_m + \phi)$

l_3 is the effective length beyond the end of the bend or first bend

For anchorages with two bends l_3 can be taken as the length from the end of the first bend to the end of the second bend $\leq 12\phi$, provided that the lower straight section is not relied upon as compression reinforcement. For anchorages with single bends l_3 can be taken as the actual length $\leq 12\phi$.

The design resistance calculated as the lesser of $F_{s,Rd1}$ and $F_{s,Rd2}$ is the force that can be transferred from a bar to the concrete in contact with it and is specific to the details of the continuity reinforcement and the concrete surrounding it. The further transmission of this force and the others at the end of the slab to the parts of the wall above and below it depends on the distributions of these forces and on the wider detailing of the wall/floor joint, which may be approached by strut and tie modelling or other appropriate methods.

7 Quality Assurance

DYWIDAG-Systems International recostal® RSH Key Profiled EC2 Starter Pack reinforcement continuity system is produced under a BS EN ISO 9001 quality management system certified by CARES. The quality management system scheme monitors the production of the continuity system and ensures that materials and geometry remain within the limits of this technical approval.



8 Building Regulations

8.1 The Building Regulations (England and Wales)

Structure, Approved Document A

DYWIDAG-Systems International recostal® RSH Key Profiled EC2 Starter Pack reinforcement continuity system, when used in EC2 based designs using the data contained within this technical approval, satisfy the relevant requirements of The Building Regulations (England and Wales), Approved Document A.

Materials and Workmanship, Approved Document

This technical approval gives assurance that the DYWIDAG-Systems International recostal® RSH Key Profiled EC2 Starter Pack reinforcement continuity system comply with the material requirements of EC2.

8.2 The Building Regulations (Northern Ireland)

Materials and Workmanship

This technical approval gives assurance that DYWIDAG-Systems International recostal® RSH Key Profiled EC2 Starter Pack reinforcement continuity system comply with the material requirements of EC2 by virtue of regulation 23, *Deemed to satisfy provisions regarding the fitness of materials and workmanship*.

8.3 The Building Standards (Scotland)

Fitness of Materials

This technical approval gives assurance that DYWIDAG-Systems International recostal® RSH Key Profiled EC2 Starter Pack reinforcement continuity system comply with the material requirements of EC2 by virtue of *Clause 0.8*.

Structure

DYWIDAG-Systems International recostal® RSH Key Profiled EC2 Starter Pack reinforcement continuity system, when used in EC2 based designs using the data contained within this technical approval, satisfy the requirements of *The Building Standards (Scotland) clause 1*.

9 References

- BS 4449: 2005 Steel bars for the reinforcement of and use in concrete - Weldable reinforcing steel – Bar, coil decoiled product - Specification.
- BS 8666: 2005 Scheduling, dimensioning, bending and cutting of steel reinforcement for concrete - Specification
- BS EN 1992-1-1:2004 Eurocode 2 Design of concrete structures - General rules for buildings.
- BS EN ISO9001: Quality Management Systems - Requirements.
- CARES Appendix TA2: Quality and Operations Schedule for the Technical Approval of Reinforcement Continuity Systems.
- Imperial College Test report: Load Testing of DYWIDAG-Systems International Recostal® Key Profiled EC2 EURO Starter Pack system units by A.D. Pullen May 2019.
- Dr R Vollum report: Evaluation of DYWIDAG-Systems International recostal® RSH Key Profiled EC2 Starter Pack reinforcement continuity system from tests on reinforced concrete specimens, May 2019.



10 Conditions

1. The quality of the materials and method of manufacture have been examined by CARES and found to be satisfactory. This technical approval will remain valid providing that:
 - a) The product design and specification are unchanged.
 - b) The materials, method of manufacture and location are unchanged.
 - c) The manufacturer complies with CARES regulations for technical approvals.
 - d) The manufacturer holds a valid CARES Certificate of Product Assessment.
 - e) The product is installed and used as described in this report.
2. CARES make no representation as to the presence or absence of patent rights subsisting in the product and/or the legal right of DYWIDAG-Systems International to market the product.
3. Any references to standards, codes or legislation are those which are in force at the date of this certificate.
4. Any recommendations relating to the safe use of this product are the minimum standards required when the product is used. These requirements do not purport to satisfy the requirements of the Health and Safety at Work act 1974 or any other relevant safety legislation.
5. CARES does not accept any responsibility for any loss or injury arising as a direct or indirect result of the use of this product.
6. This Technical Approval Report should be read in conjunction with CARES Certificate of Product Assessment No 5075. Confirmation that this technical approval is current can be obtained from CARES.



Electronic Copy www.carescertification.com

CARES

Pembroke House
21 Pembroke Road
Sevenoaks
Kent TN13 1XR

Phone: +44(0)1732 450000
E-mail: general@carescertification.com
www.carescertification.com



**Independent Product Assessments
for the Construction Industry**

Copyright CARES ©